

END MILL ADAPTERS - BT30

EA PART NUMBER	A DIA.	B DIA.	C	D	E	F	SET SCREW	ENDMILL TYPE
EABT30E-018-250	.1875	.68	2.50	----	.44	----	1/4-28W	SINGLE OR DOUBLE END
EABT30E-025-250	.250	.875	2.50	----	.44	----	1/4-28W	
EABT30E-038-250	.375	1.00	2.50	----	.75	----	3/8-24W	
EABT30E-050-250	.500	1.25	2.50	2.00	.88	----	7/16-20W	SINGLE END
EABT30E-062-300	.625	1.50	3.00	2.62	.94	----	9/16-18W	
EABT30E-075-300	.750	1.75	3.00	2.63	1.00	----	5/8-18W	
EABT30E-088-400	.875	2.00	4.00	3.13	1.00	.81	5/8-18W	
EABT30E-100-400	1.000	2.00	4.00	2.50	1.12	1.00	3/4-16W	

Order retention knobs separately, specify machine make and model#.

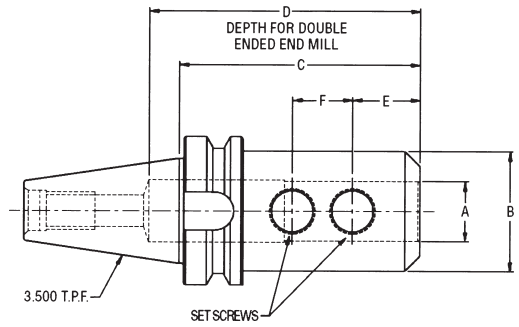

TG COLLET CHUCKS - BT30

EA PART NUMBER	COLLET SERIES	A COLLET RANGE	B DIA.	C	D	COLLET NUT	STOP SCREW	COLLET NUT WRENCH
EABT30CH-075-300	TG075	.062-.750	2.18	3.00	3.12	EATGCN-075	----	EATG075HW

Order retention knobs separately, specify machine make and model#.

Includes collet nut and standard stop screw. Purchase collets and wrenches separately.

Note! Collet must be assembled into collet nut before inserting tool or assembling onto chuck.

Note! Do not exceed the following torque recommendations. TG75 - 60ft/lbs

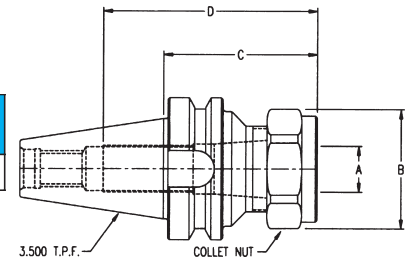

ER COLLET CHUCKS - BT30

EA PART NUMBER	COLLET SERIES	A COLLET RANGE	B DIA.	C	D	COLLET NUT	STOP SCREW	COLLET NUT WRENCH
EABT30ER-16-275	ER16	.019-.393	1.10	2.75	3.00	EAERCN-16	7/16-LH	EAER16HW
EABT30ER-32-275	ER32	.078-.787	1.97	2.75	2.75	EAERCN-32	----	EAER32SW

Order retention knobs separately, specify machine make and model#.

Includes collet nut and standard stop screw. Purchase collets and wrenches separately.

Note! Collet must be assembled into collet nut before inserting tool or assembling onto chuck.

Note! Do not exceed the following torque recommendations. ER16 - 40ft/lbs ER32 - 80ft/lbs

