

BORING BAR HOLDER, TYPE T1 EXTERNAL, INTERNAL COOLANT SUPPLY

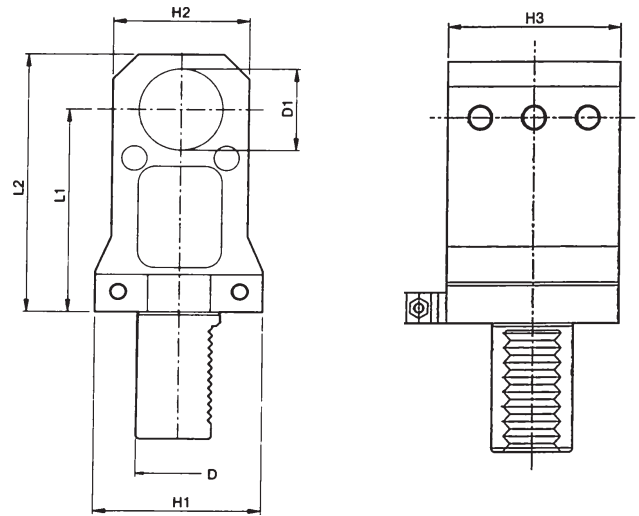

EA PART NUMBER	D	D1	H1	H2	H3	L1	L2
VDI T1-30-1.25"-65	30	1.25"	65	52	62	65	90
VDI T1-30-1.25"-85	30	1.25"	65	52	62	85	108
VDI T1-30-1.25"-100	30	1.25"	65	52	62	100	123
VDI T1-30-1.25"-120	30	1.25"	65	52	62	120	143
VDI T1-40-1.5"-85	40	1.5"	80	65	85	85	112
VDI T1-40-1.5"-100	40	1.5"	80	65	85	100	127

REVOLVING STOCK STOP

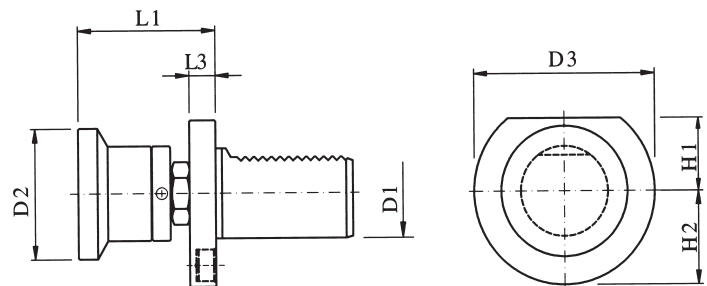

EA PART NUMBER	D1	D2	D3	H1	H2	L1	L3
E201.040.160	20	45	50	23	23	40 - 70	9
E217.045.220	25	45	50	23	23	40 - 70	9
E202.040.090	30	58	68	28	30	61 - 97	11
E202.045.100	30	26	68	28	30	62 - 95	20
E203.040.220	40	58	83	32.5	---	62 - 95	12