

**RECTANGULAR TOOL HOLDER, FORM D1**  
 with multiple seats

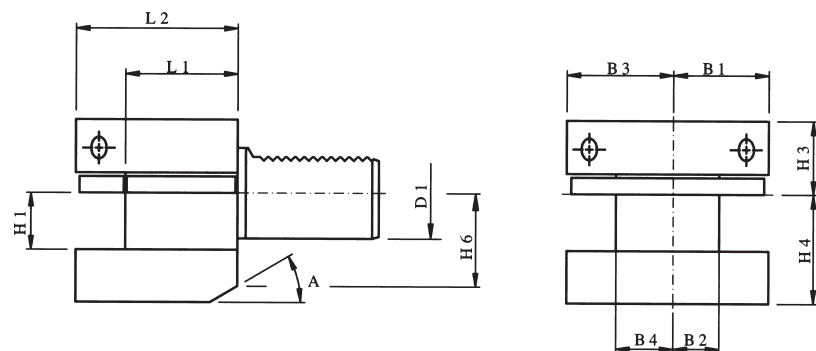

EA PART NUMBER	D1	H1 -0.1MM	DIN DESIGNATION	B1	B2 +0.5	B3	B4 +0.5	H3	H4	H6	L1 +0.5	L2	A
E217.135.250	25	5/8	D1-25	33	19	33	19	22	30	25	34	48	30
E212.135.250	30	3/4	D1-30	35	17	41	23	28	38	30	42	60	25
E213.135.250	40	1	D1-40	42.5	20.5	47.5	25.5	32.5	48	----	50	72	----
E214.135.250	50	1-1/4	D1-50	50	25.5	55	30.5	35	60	----	60	85	----
E215.135.250	60	1-1/4	D1-60	57.5	32.5	57.5	32.5	42.5	62.5	----	85	110	----

**RECTANGULAR TOOL HOLDER, FORM D2**  
 with multiple seats, overhead

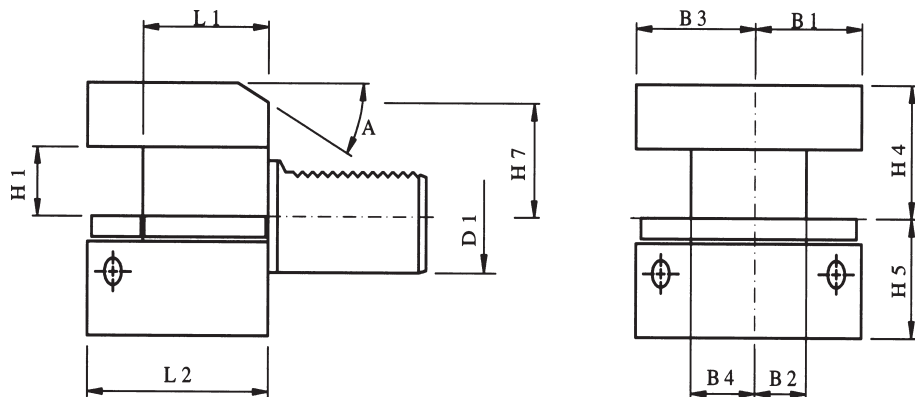

EA PART NUMBER	D1	H1 -0.1	DIN-DESIGNATION	B1	B2 +0.5	B3	B4 +0.5	H4	H5	H7	L1 +0.5	L2	A
E217.140.250	25	5/8	D2-25	33	19	33	19	30	25	25	34	48	30
E212.140.250	30	3/4	D2-30	35	17	41	23	38	35	28	42	60	25
E213.140.250	40	1	D2-40	42.5	20.5	47.5	25.5	48	42.5	----	50	72	----
E214.140.250	50	1-1/4	D2-50	50	25.5	55	30.5	60	50	----	60	85	----
E215.140.250	60	1-1/4	D2-60	57.5	32.5	57.5	32.5	62.5	62.5	----	85	100	----