

BLANKING PLUG, FORM Z2

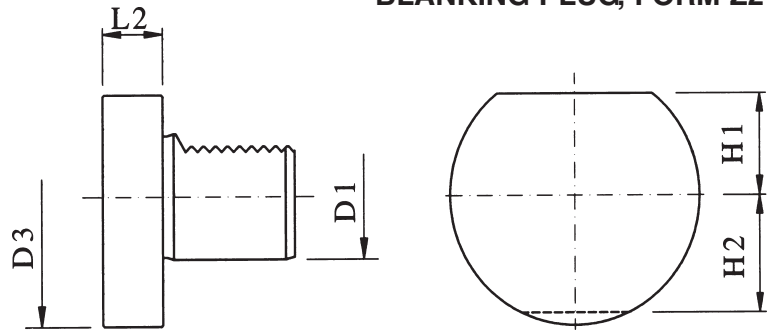

EA PART NUMBER	D1	DIN-DESIGNATION	D3	H1	H2	L2	MATERIAL
E210.500.150	16	Z2-16	40	18	23	13	STEEL
E210.500.001	16	Z2-16	40	18	23	13	PLASTIC
E211.500.150	20	Z2-20	50	23	23	16	STEEL
E211.500.001	20	Z2-20	50	23	23	16	PLASTIC
E217.500.150	25	Z2-25	58	25	25	16	STEEL
E217.500.001	25	Z2-25	58	25	25	16	PLASTIC
E212.500.150	30	Z2-30	68	28	30	16	STEEL
E212.500.001	30	Z2-30	68	28	30	16	PLASTIC
E213.500.150	40	Z2-40	83	32.5	----	20	STEEL
E213.500.001	40	Z2-40	83	32.5	----	20	PLASTIC
E214.500.150	50	Z2-50	98	35	----	20	STEEL
E214.500.001	50	Z2-50	98	35	----	20	PLASTIC
E215.500.150	60	Z2-60	123	42.5	----	20	STEEL
E215.500.001	60	Z2-60	123	42.5	----	20	PLASTIC

CLAMPING RING, FORM Z1

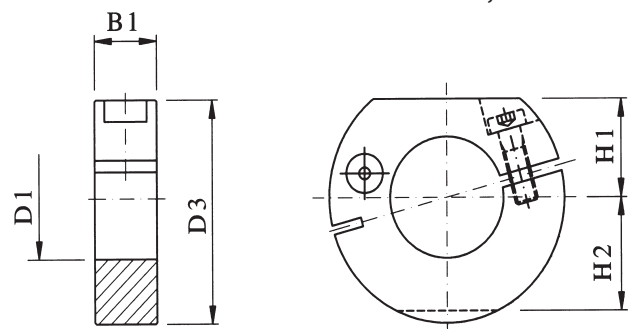

EA PART NUMBER	D1	DIN-DESIGNATION	D3	H1	H2	B1
E201.020.150	20	Z1-20	50	23	23	16
E202.020.150	30	Z1-30	68	28	30	22
E203.030.150	40	Z1-40	83	32.5	----	22
E204.040.150	50	Z1-50	98	35	----	30
E205.020.150	60	Z1-60	123	42.5	----	30