



EDWARD ANDREWS INTERNATIONAL

"Tooling and Workholding Specialist in the Metal Cutting Industry"

STERLING HEIGHTS, MICHIGAN

VDI ORIENTATION CHART

CLOCKWISE SPINDLE
ROTATION

Tools **NOT** In Parenthesis Mounted With Tool
Shank Teeth Up. (**Tools IN Parenthesis Mounted
With Tool Shank Teeth Down.**) Check Your
Turret For Which Way Your Tools Mount.

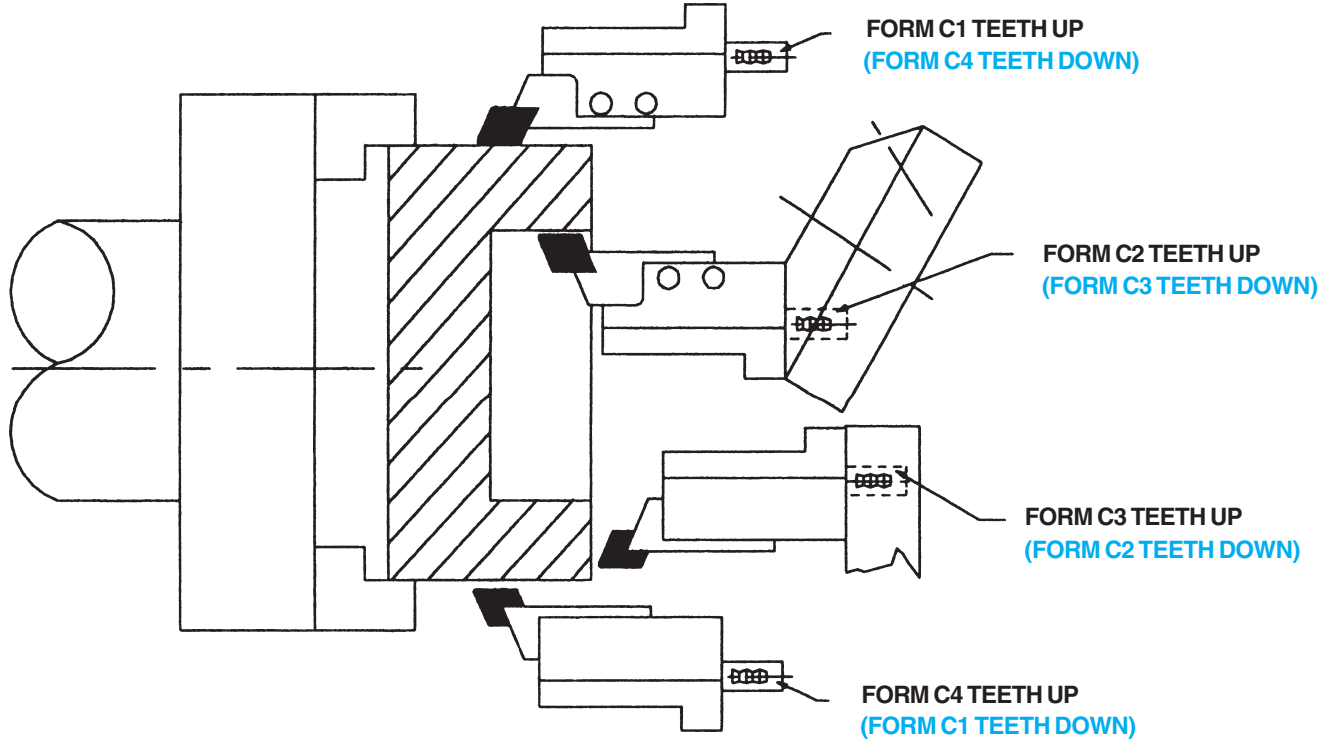

EDWARD ANDREWS INTERNATIONAL

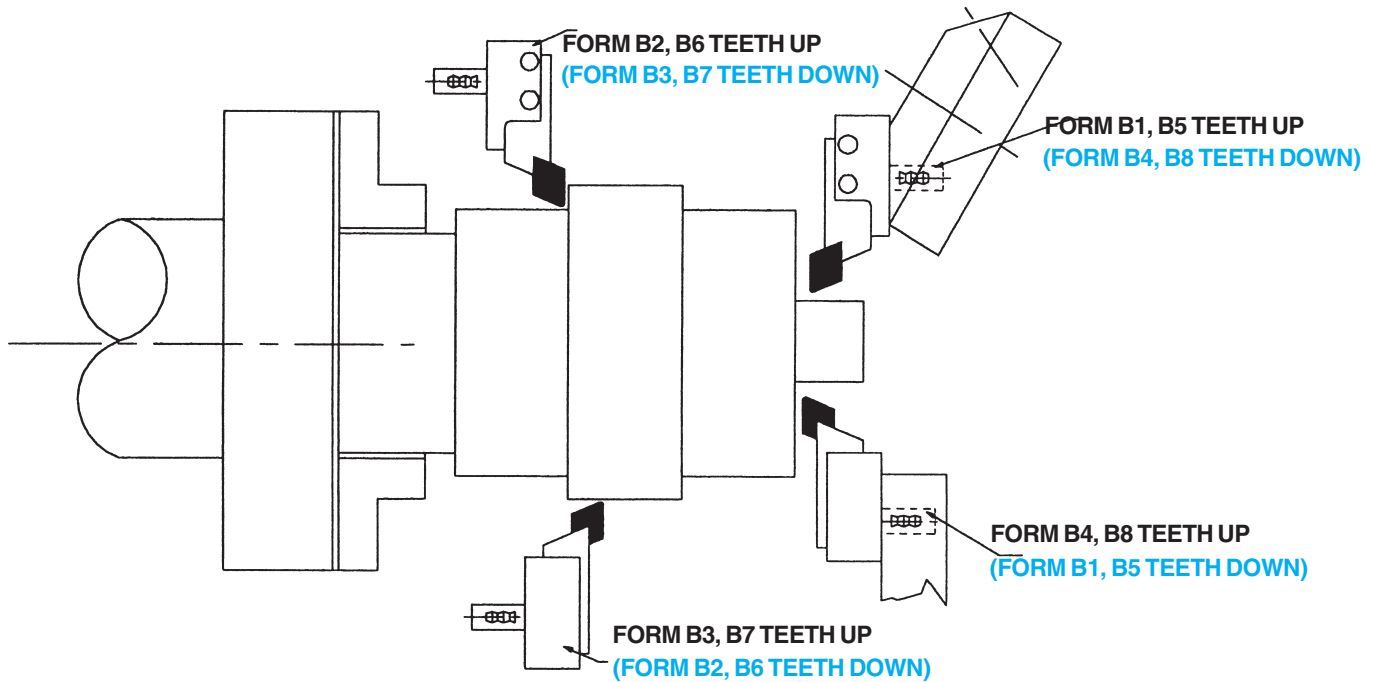

Tools **NOT** In Parenthesis Mounted With Tool Shank Teeth Up. (Tools **IN** Parenthesis Mounted With Tool Shank Teeth Down.) Check Your Turret For Which Way Your Tools Mount.

VDI ORIENTATION CHART COUNTER-CLOCKWISE SPINDLE ROTATION

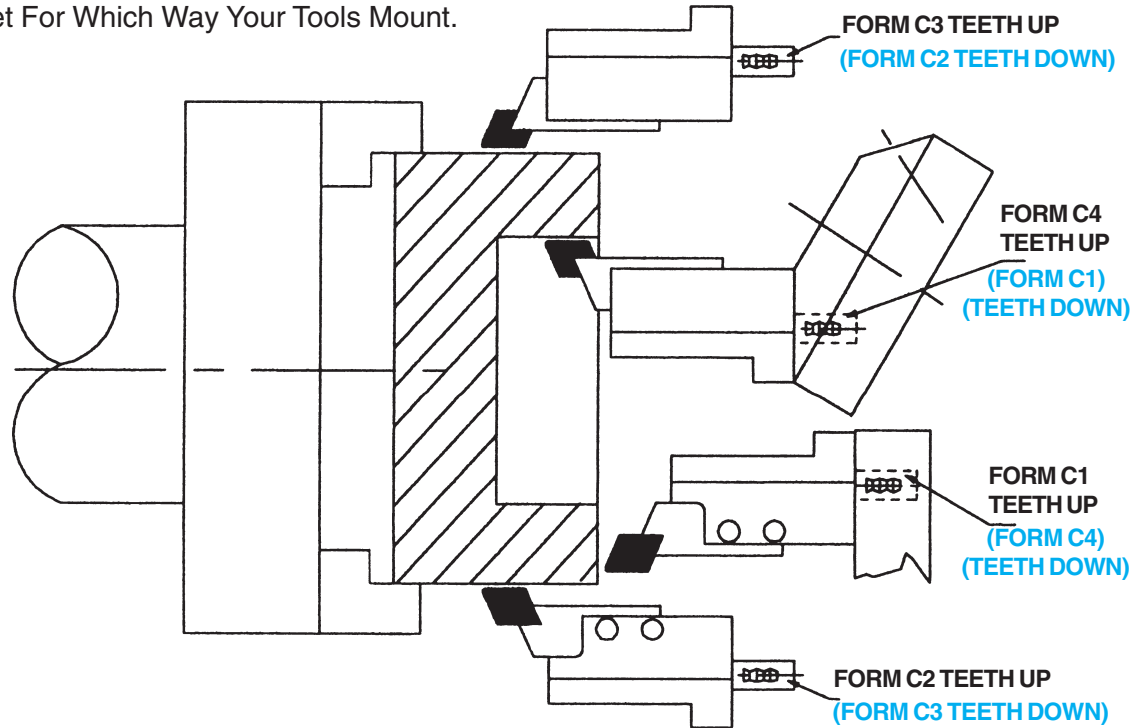

EDWARD ANDREWS INTERNATIONAL

