

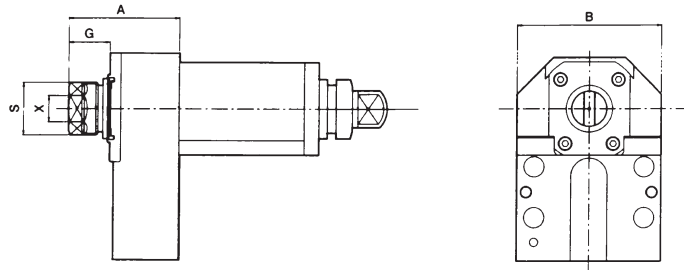

**AXIAL MILLING AND DRILLING HEAD FOR MORI SEIKI**

- Uses ER collets
- External coolant supply
- Collet is not included



EA PART NUMBER	MODELS	X CAPACITY		S	MAX RPM	A	B	C
VDN E150-0105	SL150 DL150 ZL150	1-13	ER20	35	4000	52	86	18
VDN E250-3115	SL200 DL250 ZL200	2-20	ER32	50	4000	61	100	31

**RADIAL MILLING AND DRILLING HEAD FOR MORI SEIKI**

- Uses ER collets
- External coolant supply
- Collet is not included

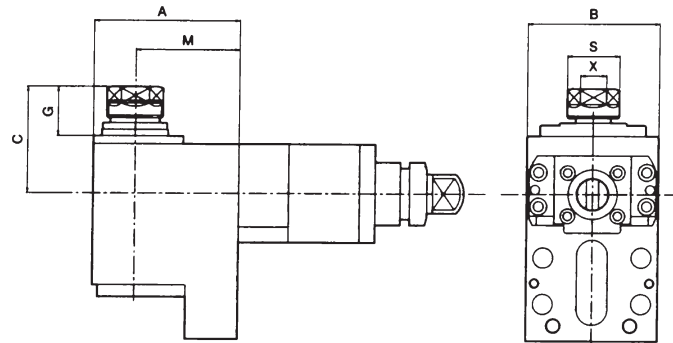

EA PART NUMBER	MODELS	X CAPACITY		S	MAX RPM	A	B	C	G	M
VDN E150-32106	SL150 DL150 ZL150	1-13	ER20	35	3500	87	86	91.5	29	67.5
VDN E250-32114	SL200 DL250 ZL200	2-20	ER32	50	3500	93	100	92.5	44.5	55

NOTE: OUTPUT ROTATION IS OPPOSITE INPUT ROTATION.

**RADIAL MILLING AND DRILLING HEAD FOR MORI SEIKI**  
 (SPINDLE 2)

- Uses ER collets
- External coolant supply
- Collet is not included

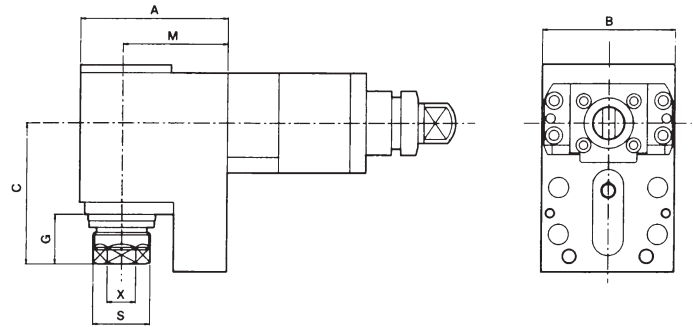

EA PART NUMBER	MODELS	X CAPACITY		S	MAX RPM	A	B	C	G	M
VDN E150-32110	SL150 DL150 ZL150	1-13	ER20	35	3500	87	86	91.5	27	67.5
VDN E250-32121	SL200 DL250 ZL200	2-20	ER32	50	3500	97	100	95	35	60

NOTE: OUTPUT ROTATION IS OPPOSITE INPUT ROTATION.