

H TYPE MILLING AND DRILLING HEAD FOR MAZAK SUPER QUICK TURN FOR 1ST SPINDLE

- Uses ER collets
- External coolant supply
- Collet is not included

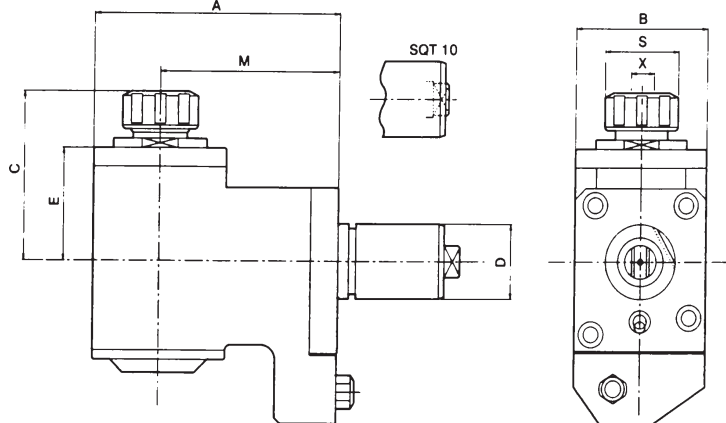

EA PART NUMBER	MACHINE TYPE	MODELS	D	X CAPACITY		S	MAX RPM	A	B	C	E	M
VDI 5352100	SQT10M-12D 15M-16D SQT200M-16D 250M-16D	SQT 10	40	1-16	ER25	42	5000	137	75	90	60	100
VDI 5362100	DQT15M-12D 18M-12D	SQT 15/18	40	1-16	ER25	42	5000	167	80	90	60	130
VDI 5362132	SQT200M-12D 250M-12D		40	2-20	ER32	50	5000	167	80	92	60	130
VDI 5382002		SQT 28/30	50	2-20	ER32	50	5000	200	90	122	85	160

NOTE: OUTPUT ROTATION IS OPPOSITE INPUT ROTATION.
H TYPE TENSION COMPRESSION TAPPING HEADS ALSO AVAILABLE.

H TYPE BACK MILLING AND DRILLING HEAD FOR MAZAK QUICK TURN FOR 2ND SPINDLE

- Uses ER collets
- External coolant supply
- Collet is not included

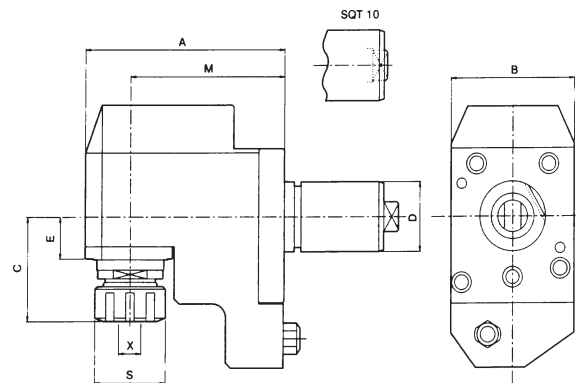

EA PART NUMBER	MACHINE TYPE	MODELS	D	X CAPACITY		S	MAX RPM	A	B	C	E	M
VDI 5354300	SQT10M-12D 15M-16D SQT200M-16D 250M-16D	SQT 10	40	1-16	ER25	42	5000	119	75	60	24.5	92
VDI 5364300	SQT15M-12D 18M-12D	SQT 15/18	40	1-16	ER25	42	5000	162	80	57	22.5	125
VDI 5364332	SQT200M-12D 250M-12D		40	2-20	ER32	50	5000	162	80	58	22.5	125
VDI 5384900		SQT 28/30	50	2-20	ER32	50	5000	197	90	81	49	160

NOTE: OUTPUT ROTATION IS OPPOSITE INPUT ROTATION.
H TYPE BACK TENSION COMPRESSION TAPPING HEADS ALSO AVAILABLE.



H TYPE MILLING AND DRILLING HEAD FOR MAZAK SUPER QUICK TURN FOR 1ST AND 2ND SPINDLE

- Uses ER collets
- External coolant supply
- Collet is not included

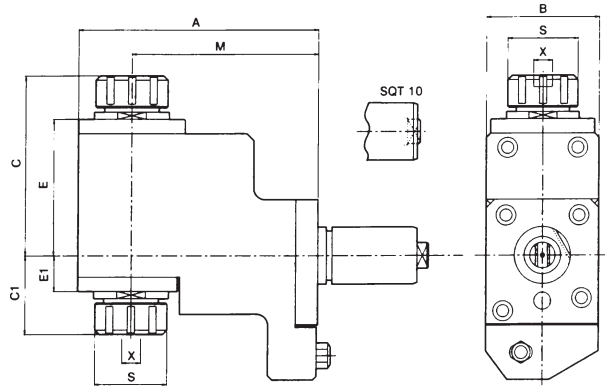

EA PART NUMBER	MACHINE TYPE	MODELS	D	X CAPACITY	S	MAX RPM	A	B	C	C1	E	E1	M
VDI 5352111	SQT10M-12D 15M-16D SQT200M-16D 250M-16D	SQT 10	40	1ST ER25 2ND ER20	42 35	4000	130	75	103	77.5	37	16	100
VDI 536411	SQT15M-12D 18M-12D SQT200M-12D 250M-12D	SQT 15/18	40	1-16 ER25	42	4000	167	80	119	50	89	19	130
VDI 5384666		SQT 28/30	50	2-20 ER32	50	4000	200	90	137	77	100	39.5	160

NOTE: ON ONE SIDE OF TOOL OUTPUT ROTATION IS THE SAME AS INPUT ROTATION, BUT ON THE OTHER SIDE, OUTPUT ROTATION IS OPPOSITE OF INPUT ROTATION.

OFFSET V TYPE MILLING AND DRILLING HEAD FOR MAZAK QUICK TURN

- Uses ER collets
- External coolant supply
- Collet is not included

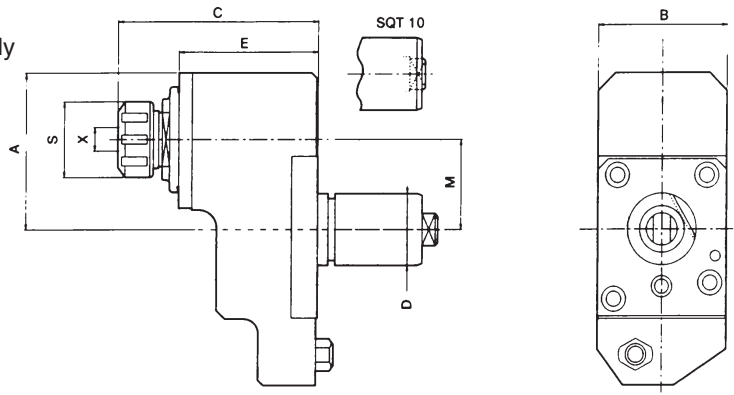

EA PART NUMBER	MACHINE TYPE	MODELS	D	X CAPACITY	S	MAX RPM	A	B	C	E	M
VDI 5352700	SQT10M-12D 15M-16D SQT200M-16D 250M-16D	SQT 10	40	1-16 ER25	42	5000	88	75	113	79	50
VDI 5362200	SQT15M-12D 18M-12D SQT200M-12D 250M-12D	SQT 15/18	40	1-16 ER25	42	5000	89	80	116	81.5	50
VDI 5362232			40	2-20 ER32	50	5000	89	80	122	81.5	50
VDI 5382100		SQT 28/30	50	2-20 ER32	50	5000	95	96	132	91	70

NOTE: OUTPUT ROTATION IS OPPOSITE INPUT ROTATION.
 OFFSET V TYPE TENSION COMPRESSION TAPPING HEADS ALSO AVAILABLE.

V TYPE MILLING AND DRILLING HEAD FOR MAZAK SUPER QUICK TURN

- Uses ER collets
- External coolant supply
- Collet is not included

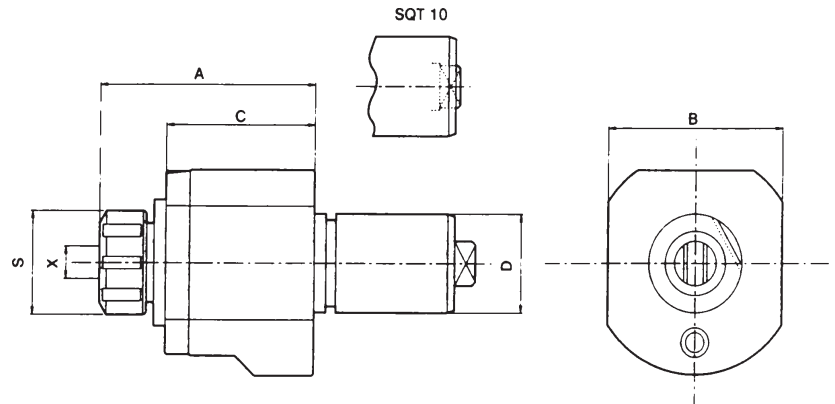

EA PART NUMBER	MACHINE TYPE	MODELS	D	X CAPACITY		S	MAX RPM	A	B	C
VDI 5352200	SQT10M-12D 15M-16D SQT200M-16D 250M-16D	SQT 10	40	1-16	ER25	42	6000	91	75	59
VDI 5362218	SQT15M-12D 18M-12D SQT200M-12D 250M-12D	SQT 15/18	40	2-20	ER32	50	6000	117	80	80

V TYPE TENSION COMPRESSION TAPPING HEADS ALSO AVAILABLE.

V TYPE LONG MILLING AND DRILLING HEAD FOR MAZAK SUPER QUICK TURN

- Uses ER collets
- External coolant supply
- Collet is not included

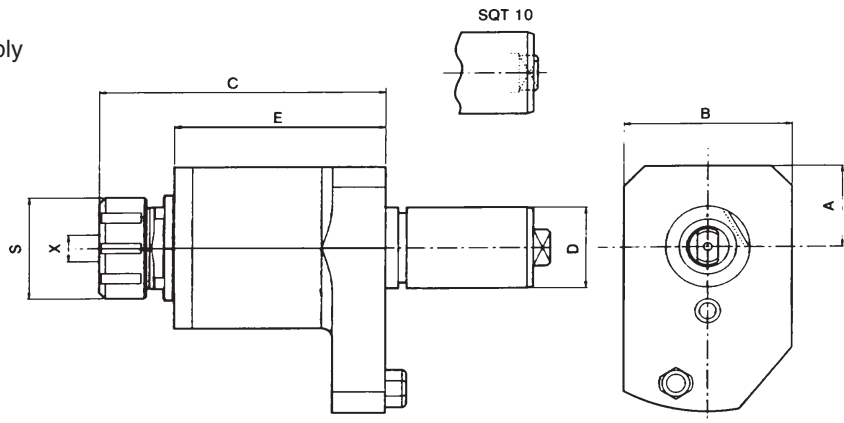

EA PART NUMBER	MACHINE TYPE	MODELS	D	X CAPACITY		S	MAX RPM	A	B	C	E
VDI 5362632-L	SQT15M-12D 18M-12D SQT200M-12D 250M-12D	SQT 15/18	40	2-20	ER32	50	6000	40	80	133.5	98.5