

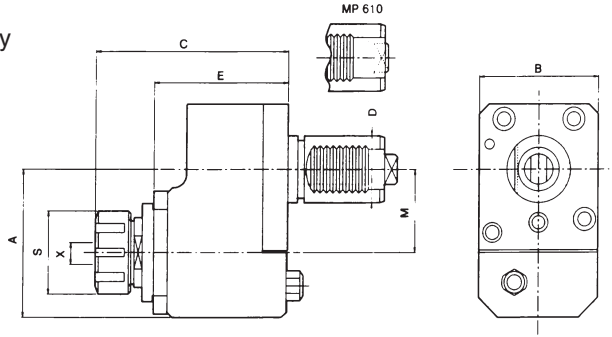

OFFSET V TYPE MILLING AND DRILLING HEAD FOR MAZAK MULTIPLEX

- Uses ER collets
- External coolant supply
- Collet is not included



EA PART NUMBER	MACHINE TYPE	MODELS	D	X CAPACITY		S	MAX RPM	A	B	C	E	M
VDI 5346100	MP410N-12D 415N-12D MP610-12D 6200-16D	MP 610	40	1-16	ER25	42	5000	89	75	118	82.5	50
VDI 5347200	MP420N-12D 620N-12D MP620-12D 6200-16D	MP 620	40	1-16	ER25	42	5000	89	80	116	81.5	50
VDI 5347232			40	2-20	ER32	50	5000	89	80	118	81.5	50

NOTE: OUTPUT ROTATION IS OPPOSITE INPUT ROTATION.
 OFFSET V TYPE TENSION COMPRESSION TAPPING HEADS ALSO AVAILABLE.

V TYPE MILLING AND DRILLING HEAD FOR MAZAK MULTIPLEX

- Uses ER collets
- External coolant supply
- Collet is not included

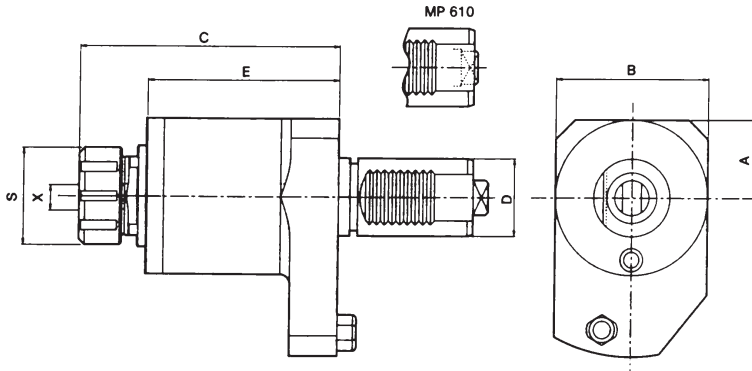

EA PART NUMBER	MACHINE TYPE	MODELS	D	X CAPACITY		S	MAX RPM	A	B	C	E
VDI 5346101	MP410N-12D 415N-12D MP610-12D 6200-16D	MP 610	40	1-16	ER25	42	6000	40	75	105	74
VDI 5347202	MP420N-12D 620N-12D MP620-12D 6200-16D	MP 620	40	1-16	ER25	42	6000	40	80	105	74
VDI 5347201			40	2-20	ER32	50	6000	40	80	107	74