

## AXIAL DRILLING AND MILLING HEAD WITH IT DRIVE COUPLING

- Uses ER collets
- External coolant supply
- Collet is not included

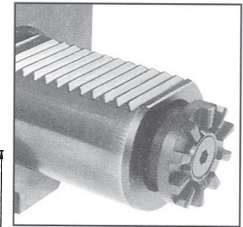
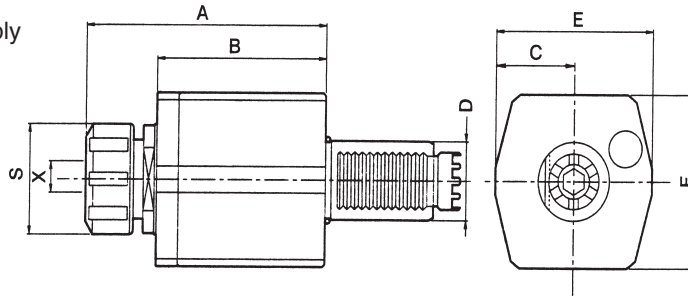

IT COUPLING

EA PART NUMBER	D DIN 69880	X CAPACITY		S	MAX RPM	i	A	B	C	E	F
VDI DA30-IT-ER25	30	1-16	ER25	42	6000	1:1	86	55	33	66	66
VDI DA40-IT-ER32	40	2-20	ER32	50	6000	1:1	89	55	39	79	78
VDI DA50-IT-ER40	50	3-26	ER40	63	6000	1:1	123	81.5	40	84	88

AXIAL TENSION COMPRESSION TAPPING HEADS ALSO AVAILABLE.

## RADIAL DRILLING AND MILLING HEAD WITH IT DRIVE COUPLING

- Uses ER collets
- External coolant supply
- Collet is not included

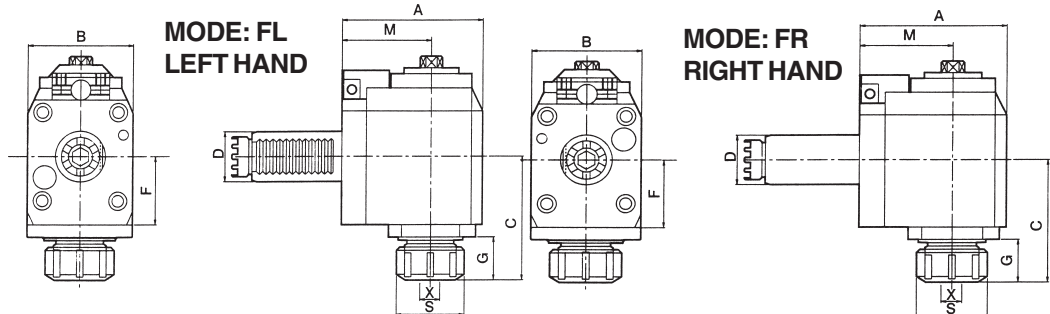

EA PART NUMBER	D DIN 69880	X CAPACITY		S	MAX RPM	i	A	B	C	F	G	M
VDI FR30-IT2565	30	1-16	ER25	42	5000	1:1	97	64	74.5	41	26	65
VDI FL30-IT2565												
VDI FR30-IT2585	30	1-16	ER25	42	5000	1:1	117	64	74.5	41	26	85
VDI FL30-IT2585												
VDI FR40-IT3265	40	2-20	ER32	50	5000	1:1	99	80	71	40	23	65
VDI FL40-IT3265												
VDI FR40-IT3285	40	2-20	ER32	50	5000	1:1	119	80	71	40	23	85
VDI FL40-IT3285												
VDI FR40-IT32100	40	2-20	ER32	50	5000	1:1	134	80	71	40	23	100
VDI FL40-IT32100												
VDI FR50-IT4075	50	3-26	ER40	60	5000	1:1	115	88	103	56	40	75
VDI FL50-IT4075												

NOTE: OUTPUT ROTATION IS OPPOSITE INPUT ROTATION.  
RADIAL TENSION COMPRESSION TAPPING HEADS ALSO AVAILABLE.