

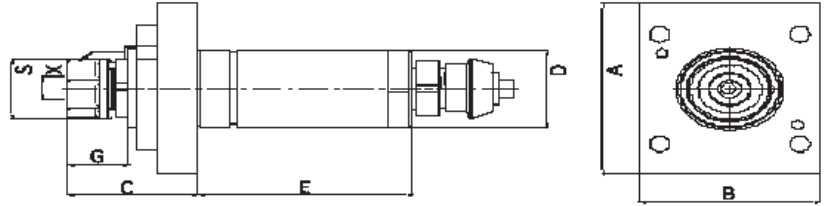

AXIAL MILLING AND DRILLING HEAD FOR MIYANO

- Uses ER collets
- External coolant supply
- Collet is not included



EA PART NUMBER	MODELS	D	X CAPACITY		S	MAX RPM	A	B	C	E	G
VDN DA38-ER20	BNE-34S BNE-51S	38	1-13	ER20	35	6000	70	74	60	57	28
VDN DA45-ER20	BNE	45	1-13	ER20	35	6000	92	72	47	81	25
VDN DA45-ER25			2-16	ER25	42	6000	92	72	53	81	31
VDN DA45-ER20-L	BND-51	45	1-13	ER20	35	6000	86	80	55	44.5	28
VDN DA45-BNJ-ER20	BNJ-42S	45	1-13	ER20	35	6000	92	72	50	116	28

RADIAL MILLING AND DRILLING HEAD FOR MIYANO

- Uses ER collets
- External coolant supply
- Collet is not included

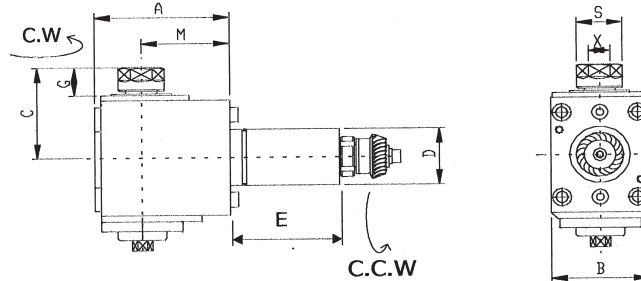

EA PART NUMBER	MODELS	D	X CAPACITY		S	MAX RPM	A	B	C	E	G	M
VDN DF45-ER20	BNE	45	1-13	ER20	35	4000	95	72	74	81	24.5	65
VDN DF45-ER25			1-16	ER25	42	4000	95	72	79	81	25.5	65
VDN DF45-ER20-L	BND-51	45	1-13	ER20	35	4000	95	80	72	44.5	25	65
VDN DF45-BNJ-ER20	BNJ-42S	45	1-13	ER20	35	4000	95	72	74	116	24.5	65

DOUBLE COLLET RADIAL MILLING AND DRILLING HEAD FOR MIYANO

- Uses ER collets
- External coolant supply
- Collet is not included

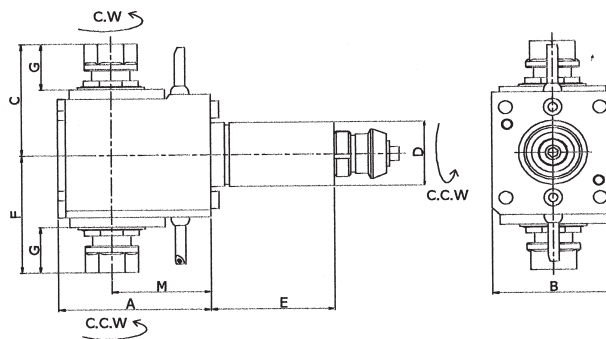

EA PART NUMBER	MODELS	D	X CAPACITY		S	MAX RPM	A	B	C	E	F	G	M
VDN DF45-20-65D	BNE	45	1-13	ER20	35	4000	100	80	79	81	83	32.5	65



OFFSET RADIAL DRILLING AND MILLING HEAD FOR MIYANO

- Uses ER collets
- External coolant supply
- Collet is not included

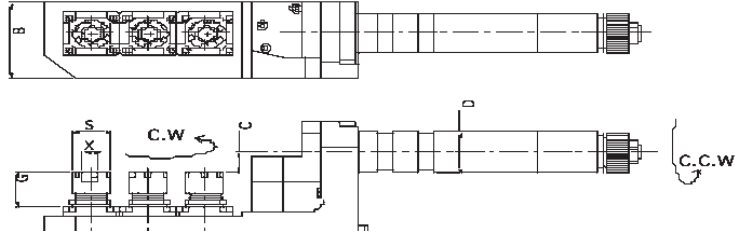

EA PART NUMBER	MODELS	D	X CAPACITY		S	MAX RPM	A	B	C	G	M
VDN DB38-ER20	BNE-34S BNE-51S	38	1-13	ER20	35	3500	112	74	18	17	90