



EDWARD ANDREWS INTERNATIONAL

"Tooling and Workholding Specialist in the Metal Cutting Industry"

STERLING HEIGHTS, MICHIGAN

TOOL HOLDER BUSHINGS

STYLE "LB"

EDWARD ANDREWS "LB" Style Tool Holder Bushings are manufactured with four set screw clearance holes and clearance notches for coolant. These bushings are designed to fit in tool blocks used on Okuma lathe models LB-15, LB-25, LU-15, and LU-25. These bushings are available with either inch or metric O.D.

MADE IN THE U.S.A. OF THRU HARDENED ALLOY AND PRECISION GROUND.

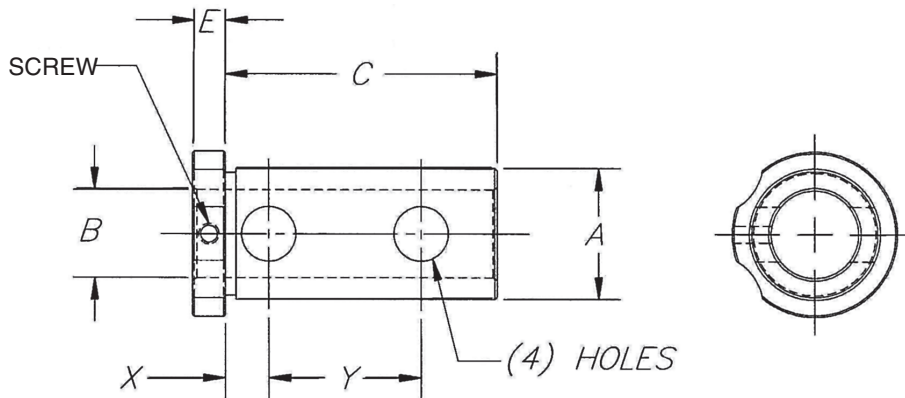

INCH OD

EA PART NUMBER	BUSHING DIA.	STANDARD BORE SIZES STOCKED*	LENGTH UNDER HEAD	HEAD THICKNESS	LENGTH DIMENSIONS	
	A				B	X
EA68-13LB	1-1/2	3/8, 1/2, 5/8, 3/4, 1, 1-1/4	3-1/8	3/8	1/2	1-3/4

METRIC OD

EA68-83LB	40MM	3/8, 1/2, 5/8, 3/4, 1, 1-1/4	3-1/8	3/8	1/2	1-3/4
-----------	------	------------------------------	-------	-----	-----	-------

*Special Sizes Available.

WHEN ORDERING BUSHINGS, SPECIFY EA PART NUMBER AND BORE SIZE REQUIRED.