

TOOL HOLDER BUSHINGS

STYLE "B"

EDWARD ANDREWS Premium Style "B" Bushings are used to adapt drills, boring bars or shank type tools, which do not have flats, to the standard bore of the turret or tool holder on the machine.

The Style "B" Bushings are split and have a flat on the O.D. They also feature our stepped head design for easy removal.

MADE IN THE U.S.A. OF THRU HARDENED ALLOY AND PRECISION GROUND.

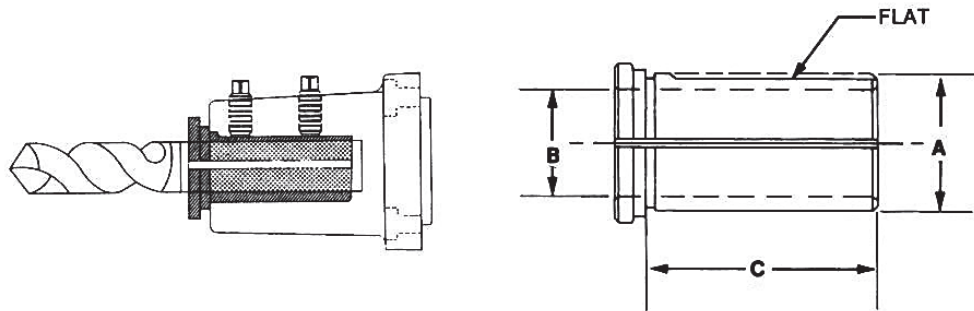

EA PART NUMBER	BUSHING DIA.	STANDARD BORE SIZE STOCKED*	LENGTH UNDER HEAD
EA68-00B	5/8	1/4, 5/16, 3/8, 1/2	1-1/2
EA68-01B	3/4	1/4, 5/16, 3/8, 1/2	1-1/2
EA68-02B	1	3/8, 1/2, 5/8, 3/4	1-3/4
EA68-12B	1-1/4	3/8, 1/2, 5/8, 3/4, 7/8, 1	2-1/8
EA68-03B	1-1/2	3/8, 1/2, 5/8, 3/4, 7/8, 1, 1-1/4	2-1/2
EA68-04B	1-3/4	1/2, 5/8, 3/4, 7/8, 1, 1-1/4, 1-1/2	3
EA68-05B	2	1/2, 5/8, 3/4, 7/8, 1, 1-1/4, 1-1/2, 1-3/4	3-1/2
EA68-06B	2-1/2	1/2, 5/8, 3/4, 7/8, 1, 1-1/4, 1-1/2, 1-3/4, 2, 2-1/4	4
EA68-07B	3	1, 1-1/4, 1-1/2, 1-3/4, 2, 2-1/4, 2-1/2	4-1/2
EA68-08B	3-1/2	1, 1-1/4, 1-1/2, 1-3/4, 2, 2-1/4, 2-1/2, 3	5-1/4

* Special Sizes Available.

**CALL TO CHECK AVAILABILITY ON SPECIAL SIZES.
MANY TIMES SPECIAL SIZES ARE IN STOCK.**

WHEN ORDERING BUSHINGS, SPECIFY EA PART NUMBER AND BORE SIZE REQUIRED.