



LIVE BMT TOOLING FOR DOOSAN & HYUNDAI KIA

RADIAL DRILLING & MILLING HEAD

Milling & Drilling Head

- Uses ER Collets
- External coolant supply
- Collet not included

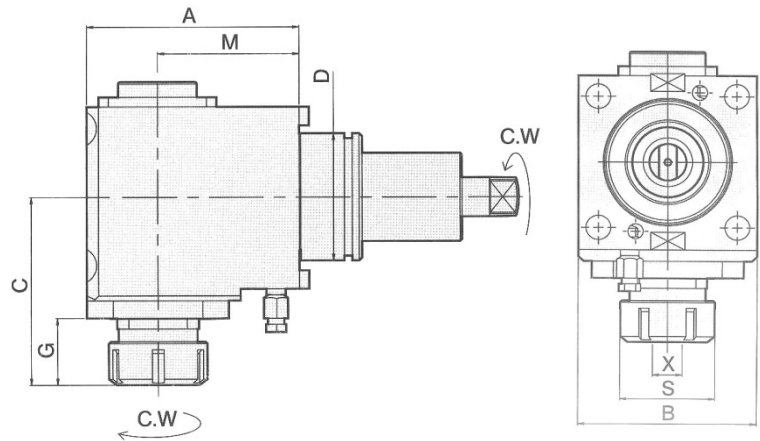

EA PART NUMBER	MACHINE MODEL NUMBER	D	X CAPACITY	S	MAX R.P.M.	A	B	C	G	M
VDN DW230-DF55-25-60	DOOSAN PUMA 230M	55	ER25 1-16	42	4000	86	85	81	31	60
VDN DW300-DF65-32-72	DOOSAN PUMA 300M, HYUNDAI KIA SKT250M / MS / LM / LMS & SKT300M / MS / LM / LMS	65	ER32 2-20	50	4000	108	94	96	34	72
VDN DW350-DF75-40-60	DOOSAN PUMA 350M	75	ER40 3-26	63	4000	115	110	106.5	39	60
VDN DW700-DF85-50-85	DOOSAN PUMA 700M	85	ER50 10-34	78	4000	136	125	141.5	50.5	85

Note: Check M dimension for proper length if this is to be used on the subspindle.

AXIAL MILLING & DRILLING HEAD

Milling & Drilling Head

- Uses ER Collets
- External coolant supply
- Collet not included

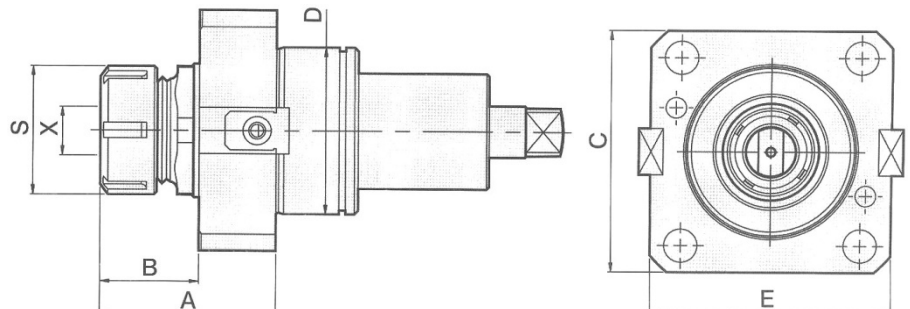

EA PART NUMBER	MACHINE MODEL NUMBER	D	X CAPACITY	S	MAX R.P.M.	A	B	C	E
VDN DW230-DA55-25	DOOSAN PUMA 230M	55	ER25 1-16	42	6000	63	33	85	85
VDN DW300-DA65-32	DOOSAN PUMA 300M, HYUNDAI KIA SKT250M / MS / LM / LMS & SKT300M / MS / LM / LMS	65	ER32 2-20	50	6000	68.5	38.5	94	94
VDN DW350-DA75-40	DOOSAN PUMA 350M	75	ER40 3-26	63	6000	79	44	110	115
VDN DW700-DA85-50	DOOSAN PUMA 700M	85	ER50 10-34	78	6000	96	56	125	125

Internal coolant tools also available.